

# 18" RCP WINGWALL

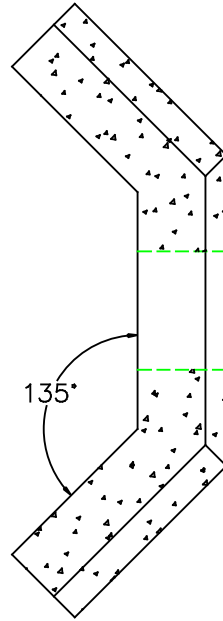

(P-52 SL SWIFT LIFT ANCHOR)

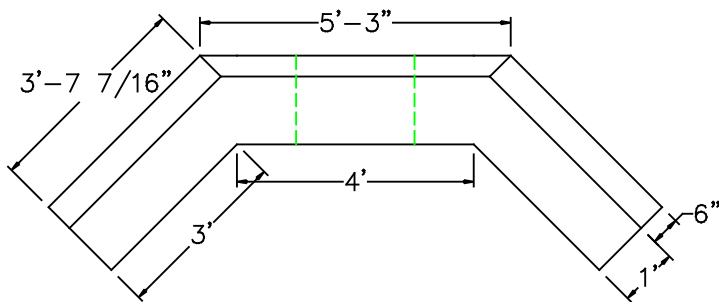
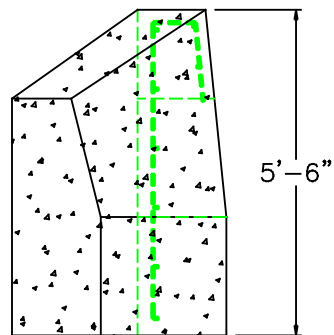
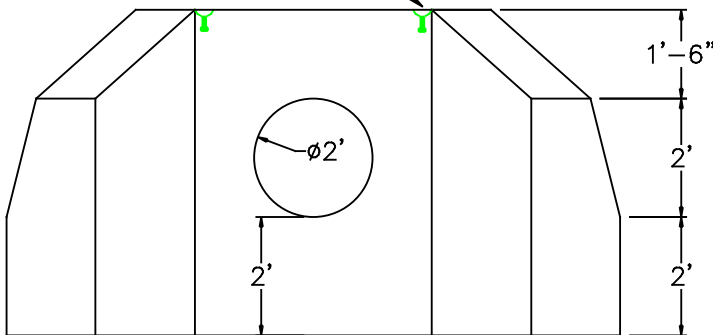

**DESIGN NOTES:**

1. CONCRETE 5,000 PSI @ 28 DAYS
2. REINFORCEMENT ASTM A-615 GRADE 60, 2" MIN. COVER #5 REBAR 12" OCBW
4. UNIT WEIGHT 10,320 lbs.



**NPCC**

**Precast ... The Concrete Solution.**

		SCITUATE RAY PRECAST 120 CLAY PIT ROAD MARSHFIELD, MA 02050 PHONE # 1-800-440-0009 FAX # 781-837-4320	
		CONTRACTOR:	JOB NAME:
DATE:	DRAWING: SRP-WW18	DRAWING BY:	C. J. SCOTT