

# 4' DIA CATCH BASIN

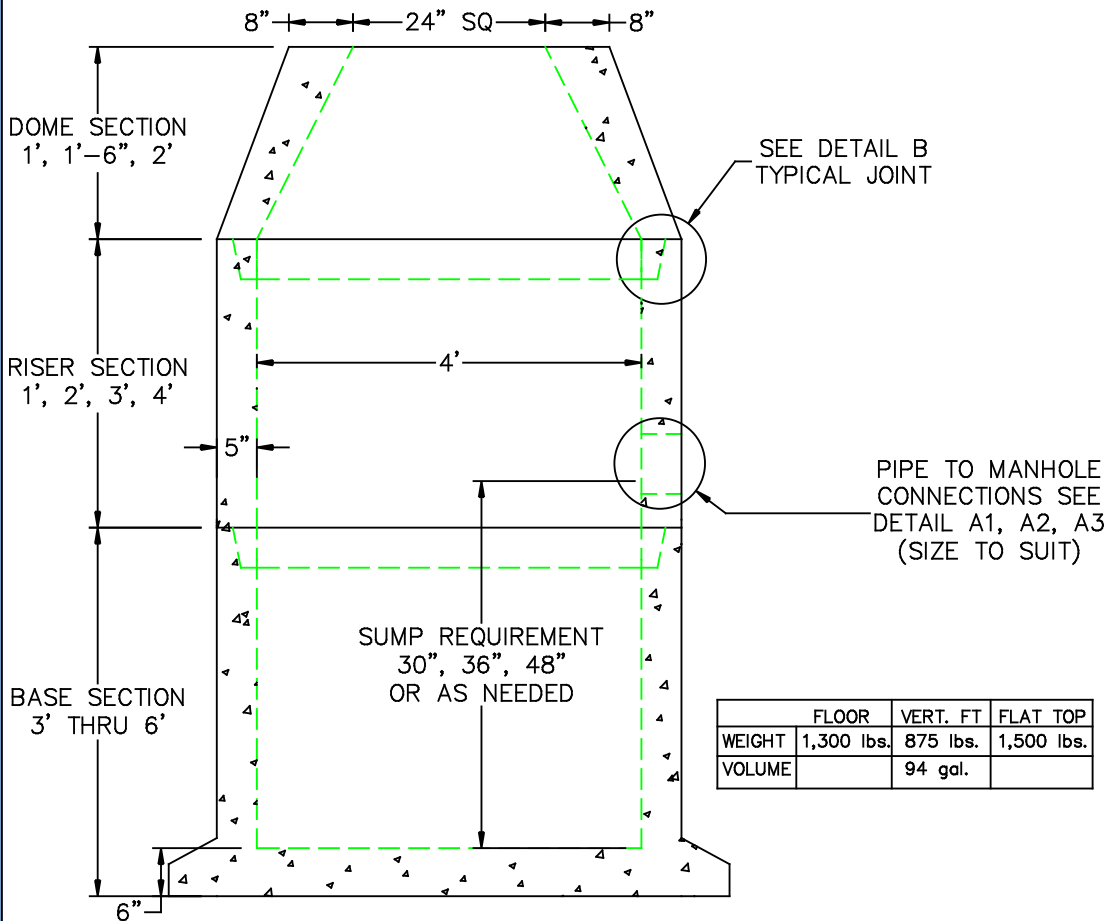
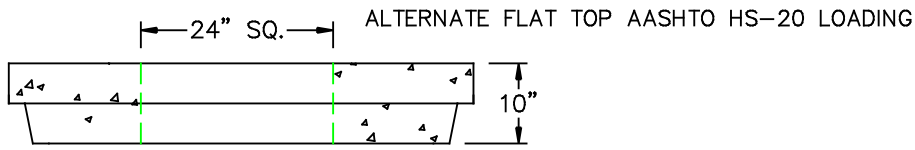

	FLOOR	VERT. FT	FLAT TOP
WEIGHT	1,300 lbs.	875 lbs.	1,500 lbs.
VOLUME		94 gal.	

A1

COMPRESSION GASKET (CAST IN)

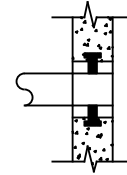

A2

FLEXIBLE SLEEVE

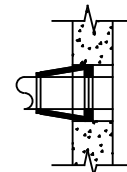

A3

MORTAR BY CONTRACTOR

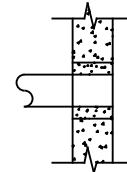

B

BUTYL RUBBER SECTION JOINT

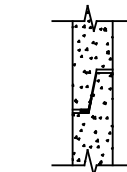

C

POLYPROPYLENE MANHOLE STEPS

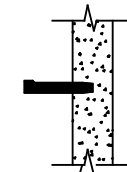

**DESIGN NOTES:**

1. MANUFACTURED TO MEET OR EXCEED: ASTM C-478 & AASHTO M 199 SPECS.
2. CONCRETE = 4,000 PSI. MINIMUM CEMENT PER ASTM C-478 (6.1)
3. REINFORCED STEEL CONFORMS TO LATEST ASTM A 185 SPECIFICATIONS.  
0.12 SQ. IN / LINEAL FT. AND 0.12 SQ. IN (BOTH WAYS) BASE BOTTOM
4. STEEL REINFORCEMENT TO MEET OR EXCEED AASHTO HS-20 LOADING
5. MANHOLE STEPS MEET LATEST OSHA REGULATION 29 CFR1910.27, SECTION 16 OF ASTM SPECIFICATION C478 AND SECTION 10 OF ASTM SPECIFICATION C497
6. BUTYL RUBBER JOINT SEALANT PER ASTM C-990 & ASHTO M-198



**NPCA**

Precast ... The Concrete Solution.



**SCITUATE  
COMPANIES**

SCITUATE RAY PRECAST  
120 CLAY PIT ROAD  
MARSHFIELD, MA 02050  
PHONE # 1-800-440-0009  
FAX # 781-837-4320

CONTRACTOR:

JOB NAME:

DATE:

DRAWING: SRP-CB4-EB

DRAWING BY: C.J. SCOTT

[WWW.SCITUATECOMPANIES.COM](http://WWW.SCITUATECOMPANIES.COM)